

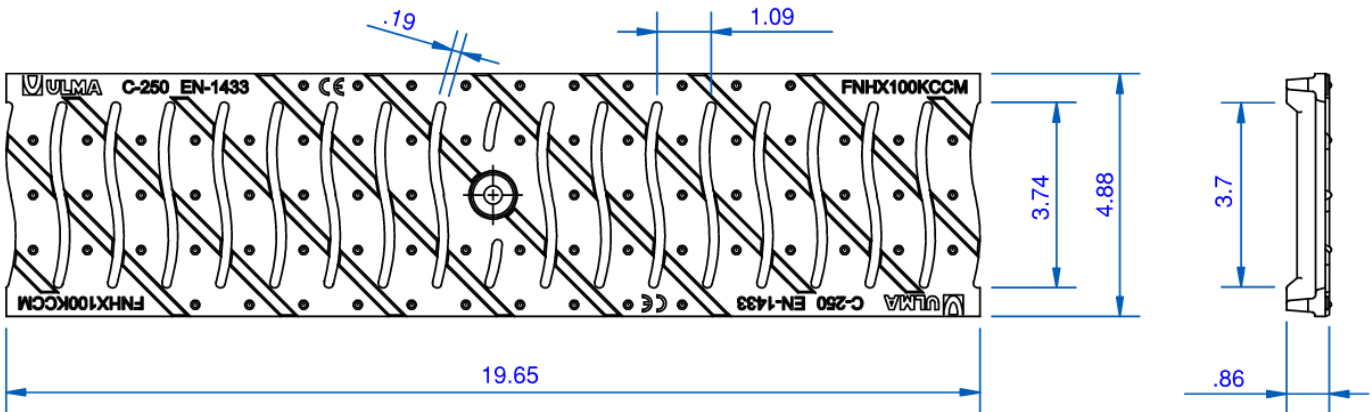

<p>Number</p> <p style="text-align: center;">FNHX100KCCM</p>	<p>Series</p> <p style="text-align: center;">D100 & U100K C Ductile Cast Iron Slotted</p>
--	---



PART NUMBER	DIMENSIONS	FREE AREA
FNHX100KCCM	19.6" [498MM]	26.9 SQ. IN.



<p>Manufacturer</p> 	<p>Specification</p> <p>ULMA FNHX100KCCM DUCTILE CAST IRON SLOTTED TRENCH DRAIN GRATE WITH CLASS C LOAD RATING (56,200 LBS.—2341 PSI), SUPPLIED BY TRENCH DRAIN SUPPLY</p>
--	---

DISCLAIMER - The customer and the customer's architects, engineers, consultants, and other professionals are completely responsible for the selection installation and maintenance of any product purchased from Trench Drain Supply and/or its manufacturers. TRENCH DRAIN SUPPLY MAKES NO WARRANTY, EXPRESS OR IMPLIED, AS TO THE SUITABILITY, DESIGN, MERCHANTABILITY, OR FITNESS OF THE PRODUCT FOR CUSTOMERS APPLICATION. The drawing and information provided remain the property and copyright of the manufacturer listed. The manufacturer reserves the right to modify specification without notice.